



MILTON ROY

EUROPE

START UP & COMMISSIONING
MANUAL



GB

GTMA - GTMM SERIES

PUMP

This manual should be made available to the person responsible for installation and the commissioning.



GTMA



GTMM

DECLARATION « CE » DE CONFORMITE

F CONFORME A LA REGLEMENTATION CI-DESSOUS

-DIRECTIVE "MACHINES"

DIRECTIVE DU CONSEIL DU 17 mai 2006 (2006/42 CEE) CONCERNANT LE RAPPROCHEMENT DES LEGISLATIONS DES ETATS MEMBRES RELATIVES AUX MACHINES.

Nous, MILTON ROY EUROPE 27360 PONT SAINT PIERRE France déclarons que le matériel désigné ci-après est en conformité avec la directive "machines" sous réserve que l'installation, l'utilisation et la maintenance soient effectuées suivant les règles de l'art et selon les prescriptions définies dans la notice d'instructions.

"EC" DECLARATION OF CONFORMITY

GB CONFORMS WITH THE REGULATIONS BELOW

- "MACHINES" DIRECTIVE

DIRECTIVE OF THE COUNCIL OF may 17, 2006 (2006/42 EEC), CONCERNING THE APPROXIMATION OF THE LAWS OF MEMBER STATES RELATIVE TO MACHINES.

We, MILTON ROY EUROPE 27360 PONT SAINT PIERRE, France hereby declare that the equipment designated below : conforms with the "machines" directive, on the condition that installation, use and maintenance are performed in keeping with recognized workmanship practices and according to the specifications given in the instruction manual.

EG-KONFORMITÄTSERKLÄRUNG

D IN KONFORMITÄT DER NACHSTEHENDEN BESTIMMUNGEN

- EG-MASCHINENRICHTLINIE

RICHTLINIE DES RATS VOM 17.mai 2006 (2006/42 EWG), BEZÜGLICH DER ANNÄHERUNG DER GESETZGEBUNGEN DER MITGLIEDSSTAATEN AUF DEM GEBIET DES MASCHINENWESENS.

Wir, DOSAPRO MILTON ROY 27360 PONT SAINT PIERRE FRANCE erklären, daß die nachstehend bezeichneten Gerätschaften : der EG-Maschinenrichtlinie konform ist, falls Einbau, Verwendung und Wartung fachgerecht und unter Einhaltung der in der Gebrauchsanleitung enthaltenen Vorschriften erfolgen.

EG FABRIKANTENCONFORMVERKLARING

NL CONFORM VAN HET HIERONDER VERMELDE REGLEMENT

- RICHTLIJN « MACHINES »

DOOR DE RAAD VAN DE EUROPESE UNIE OP KAN 2006 UITGEVAARDIGD ALS EG-RICHTLIJN 2006/42, INZAKE DE HARMONISATIE VAN DE WETGEVING DER LIDSTATEN BETREFFENDE MACHINES.

De ondergetekenden, MILTON ROY EUROPE 27360 PONT SAINT PIERRE ,FRANKRIJK. verklaren dat het hierna vermelde materiaal overeenstemt met de richtlijn «machines» op voorwaarde dat installatie, gebruik en onderhoud vakkundig en volgens de betreffende handleidingen plaatsvinden.

DICHIARAZIONE DI CONFORMITA' "CE"

I CONFORME DELLA NORMATIVA SOTTO DESCRITTA

- DIRETTIVA "MACCHINE"

DIRETTIVA DEL CONSIGLIO DEL 17 potere 2006 (2006/42 CEE) IN SEGUITO ALL'UNIFORMAZIONE DELLE LEGISLAZIONI DEGLI STATI MEMBRI RELATIVE ALLE MACCHINE.

La società MILTON ROY EUROPE 27360 PONT SAINT PIERRE FRANCIA dichiara che l'apparecchiatura descritta di seguito : è conforme alla eservaa "macchine", con la eserva che l'installazione, l'utilizzazione e la manutenzione vengano effettuate attenendosi alle regole d'arte e rispettando le procedure descritte nel manuale d'istruzioni.

<p style="text-align: center;">DECLARACION "CE" DE CONFORMIDAD</p> <p>E CONFORME AL LA REGLAMENTACION SIGUIENTE - DIRECTIVAS "MAQUINAS"</p> <p>DIRECTIVA DEL CONSEJO DEL 17 DE MAYO DE 2006 (2006/42 CEE) RELATIVA AL ACERCAMIENTO DE LAS LEGISLACIONES DE LOS ESTADOS MIEMBROS EN LO QUE RESPECTA A LAS MÁQUINAS.</p> <p>Nosotros, MILTON ROY EUROPE - 27360 PONT SAINT PIERRE – FRANCIA Declaramos que el matériel que a continuación se designa : cumple la directiva "máquinas" siempre y cuando la instalación, el uso y el mantenimiento sean efectuados de conformidad con la normativa profesional y cumpliendo las prescripciones del manual de instrucciones.</p>
<p style="text-align: center;">DECLARAÇÃO "CE" DE CONFORMIDADE</p> <p>P CONFORME DA REGULAMENTAÇÃO ABAIXO - DIRECTIVA "MÁQUINAS"</p> <p>DIRECTIVA DO CONSELHO DO DIA 17 DE PODER DE 2006 (2006/42 CEE) NO QUE SE REFERE À APROXIMAÇÃO DAS LEGISLAÇÕES DOS ESTADOS MEMBROS RELATIVAS ÀS MÁQUINAS.</p> <p>Nós, MILTON ROY EUROPE - 27360 Pont Saint Pierre – FRANCE , declaramos que o material designado em seguida : está em conformidade com a directiva "máquinas" sob reserva que a instalação, utilização e manutenção sejam efectuadas seguindo as regras da arte e segundo as prescrições da nota de instruções.</p>
<p style="text-align: center;">EF-OVERENSSTEMMELSESERKLÆRING</p> <p>DK I OVERENSSTEMMELSE MED I NEDENSTÅENDE BESTEMMELSER - "MASKIN"DIREKTIV</p> <p>RÅDETS DIREKTIV AF 17 ma 2006 OM INDBYRDES TILNÆRMELSE AF MEDLEMSSTATERNES LOVGIVNING OM MASKINER (2006/42/EØF).</p> <p>Underskrevne: DOSAPRO MILTON ROY - 27360 Pont Saint Pierre - FRANKRIG erklærer hermed, at nedenstående udstyr : er i overensstemmelse med "maskin"direktivet under forudsætning af, at montering, anvendelse og vedligeholdelse foregår i henhold til god faglig praksis og de i vejledningen angivne forskrifter.</p>
<p style="text-align: center;">"EG"-INTYG OM UPPFYLLANDE</p> <p>SW I ENLIGHET I NEDANSTÅENDE BESTÄMMELSE - "MASKIN"ÄDIREKTIV</p> <p>DIREKTIV FRÅN RÅDET, DEN 17 KAN 2006 (2006/42 EEC) RÖRANDE NÄRMANDE AV MEDLEMSSTATERNAS LAGSTIFTNINGAR FÖR MASKINER.</p> <p>Vi, MILTON ROY EUROPE - 27360 Pont Saint Pierre – FRANKRIKE intygar att nedan beskriven utrustning : överensstämmer med "maskin"-direktivet under förutsättning att den installareas, används och underhålls enligt konstens regler och enligt de beskrivningar som ges i användarinstruktionen.</p>
<p style="text-align: center;">"EU"-TODISTUS VAATIMUSTEN TAYTTAMISESTA</p> <p>FIN ALLAOLEVAN MÄÄRÄYKSEN MUKAISESTI - KONEDIREKTIIVI</p> <p>NEUVOSTON DIREKTIIVI, 17. Toukokuu 2006 (2006/42 EEC), KOSKIEN JÄSENVALTIOIDEN KONEISIIN LIITTYVIEN LAINSÄÄDÄNTÖJEN LÄHENTYMISTÄ.</p> <p>Me, MILTON ROY EUROPE - 27360 Pont Saint Pierre – RANSKA todistamme, että seuraavassa selostettu varustus : vastaa konedirektiiviä edellyttäen, että se asennetaan, sitä käytetään ja huolletaan sääntöjen ja käyttöohjeissa olevien selostusten mukaisesti.</p>
<p style="text-align: center;">ΔΗΛΩΣΗ ΠΙΣΤΟΤΗΤΑΣ "ΕΚ"</p> <p>GR ΣΥΜΦΩΝΑ ΜΕ ΤΟ "ΜΗΧΑΝΗΜΑΤΑ" ΡΥΘΜΙΣΗΣ ΟΔΗΓΙΑ "ΜΗΧΑΝΗΜΑΤΑ" ΟΔΗΓΙΑ ΤΟΥ ΣΥΜΒΟΥΛΙΟΥ ΤΗΣ 122ης Μπρωύ 2006 (2006/42 ΕΟΚ), ΠΟΥ ΑΦΟΡΑ ΤΗΝ ΠΡΟΣ ΕΠΙΣΗ ΤΩΝ ΝΟΜΟΘ ΕΣΙΩΝ ΤΩΝ ΚΡΑΤΩΝ ΜΕΛΩΝ ΣΧΕΤΙΚΑ ΜΕ ΤΑ ΜΗΧΑΝΗΜΑΤΑ.</p> <p>Η MILTON ROY EUROPE - 27360 PONT SAINT PIERRE – FRANCE δηλώνουμε ότι το παρακατω περιγραφόμενο μηχανημα : ειναι συμφωνο προς την οδηγια "Μηχανηματα" , με την επιφυλαξη ότι η εγκατασταση, η ρρηση και η συντηρηση του θα πραγματοποιουνται συμφωνα προς τους κανονες της τεχνης και τ ις προδιαγραφες που οριζονται από τις οδηγιες χρησης.</p>

RU "ЕС" ДЕКЛАРАЦИЯ О СООТВЕТСВИИ ПРОДУКЦИИ

ПРОДУКЦИЯ СООТВЕТСВИУЕТ НОРМАМ, ПРИВЕДЕННЫМ НИЖЕ - ДИРЕКТИВЕ О
"МЕХАНИЧЕСКИХ ИЗДЕЛИЯХ"

ДИРЕКТИВА СОВЕТА (КОНСУЛЬСТВА) ОТ 17 МАЯ, 2006 (2006/42 ЕЕС),
ОТНОСЯЩЕЙСЯ К СОБЛЮДЕНИЮ ЗАКОНОВ УЧАСТНИКОВ ОБЩЕСТВА
МЕХАНИЧЕСКИХ ИЗДЕЛИЙ (МАШИН).

МЫ, КОМПАНИЯ MILTON ROY EUROPE, адрес 27360 PONT SAINT PIERRE, ФРАНЦИЯ
НАСТОЯЩИМ ЗАЯВЛЯЕМ, ЧТО ОБОРУДОВАНИЕ ОПИСАННОЕ НИЖЕ СООТВЕТСТВУЕТ
ДИРЕКТИВЕ О «МЕХАНИЧЕСКИХ ИЗДЕЛИЯХ» ПРИ УСЛОВИИ, ЧТО ЕГО УСТАНОВКА,
ИСПОЛЬЗОВАНИЕ И ОБСЛУЖИВАНИЕ ПРОИЗВОДИЛОСЬ КВАЛИФИЦИРОВАННЫМ
ПЕРСОНАЛОМ И В СООТВЕТСВИЕ С ИНСТРУКЦИЕЙ ПО ЭКСПЛУАТАЦИИ.

Alain LAMPERIER
Production Manager





CONTENTS







I – PRECAUTIONS	8
II - DESCRIPTION	
II - 1. Unpacking and storage	10
II - 2. Description	10
II - 3. Safety and health instructions	11
II - 4. Accessories	11
III - INSTALLATION	
III - 1. Technical data	12
III - 2. Hydraulic installation	13
III - 3. Drip collection	13
III - 4. Manipulation	14
III - 5. Handling	14
III - 6. Electrical installation	15
IV – START UP	
IV - 1. Procedures before start up	16
IV - 2. Start up	16
IV - 3. Failures on start up	16

For additional information on the pump and its options, please refer to the CD-Rom delivered with the pump.

PART I - PRECAUTIONS

The following precautions should be considered while using the dosing pumps from MILTON ROY EUROPE range. Please read carefully this section before performing the installation.

	Protective clothing ALWAYS wear protective clothing, mask for the face, protective glasses and gloves while using or working next to the dosing pump. Some additional precautions should be taken in conformity with the nature of liquid being pumped. Please refer to the precaution of the MSDS provided with the liquid.
	Water pre-priming All the pumps are pre-primed with water at the factory. If the liquid to be pumped is not compatible with water, dismantle the liquid end of the pump. Dry up completely the liquid end, the check valves and the balls. Reassemble the liquid end by tightening the screws in a diagonal pattern. Fill the liquid end with the liquid to be pumped before priming the pump. (It will ease the start-up.)
	Chemical compatibility Check that the material of the liquid end is (chemically) compatible with the liquid to be pumped. Always refer to the liquid provider and to Chemical Resistance Chart for compatibility with your pump. Contact your local distributor for additional information.
	Piping connection The suction and discharge piping connection and the piping size should not be reduced. The size of the discharge piping should not be increased. Ensure that the piping is FIRMLY FIXED before use. ALWAYS use piping provided with the pump, it is specially designed for use with the pump connections. All piping should be protected and attached to avoid possible damage in case of any breakage or accidental damages. If the piping is exposed to the sun, a black UV protective piping should be considered. Check regularly the piping for cracks and replace portions when required.
	Connectors All connectors shall be tightened by hand. An additional turn of 1/8 to 1/4 of 360° might be necessary to ensure tightness. Any excessive tightening or using a tool might damage the connecting device and the seals or the liquid end. All the G™ series pumps are tightened with o-ring seals. NEVER use Teflon® tape or a sealing compound to seal the joints. The Teflon® tape can be used on injection nozzles on the 1/2" NPT side, on the connection of stainless steel liquid end, or directly on suction or discharge piping.

	<p>Installation</p> <p>Always comply with local regulations and requirements. Ensure that the installation is not obstructed. Comply with local piping regulations. Milton Roy Europe is not responsible of the pump installation.</p>
	<p>Back pressure valve / Anti-syphon valve</p> <p>If you are pumping downhill or into low or no pressure system, a back pressure/antisiphon device such as Four-Function Valve should be installed to prevent over pumping or siphoning. Contact your distributor for further information.</p>
	<p>Electrical installation</p> <p>WARNING: To reduce the risk of electrical shock, the metering pump must be plugged into a properly grounded grounding-type receptacle with ratings conforming to the data on the pump nameplate. The pump must be connected to a good ground. Do not use adapters! All wiring must conform to local electrical codes. If the supply cord is damaged, it must be replaced by the manufacturer, stocking distributor, or authorized repair center in order to avoid a hazard.</p>
	<p>Line Depressurization</p> <p>To reduce the risk of chemical splash during disassembly or maintenance, all installations should be equipped with line depressurization capability. Using Four-Function Valve (-FV) is one way to include this feature.</p>
	<p>Ground Fault Circuit Interrupter</p> <p>WARNING: To reduce the risk of electric shock, install only on a circuit protected by a Ground Fault Circuit Interrupter (GFCI).</p>
	<p>Clean less</p> <p>The pump should be clean and dust should be wiped off.</p>
	<p>Weight</p> <p>If the weight of the pump is over 25Kg use adequate means to manipulate/transport it.</p>

PART II - DESCRIPTION

II - 1. UNPACKING AND STORAGE

II - 1.1 UNPACKING

The packaging must be carefully examined on receipt in order to ensure that the contents have not sustained any obvious damage. Precautions must be taken when opening the packaging in order to avoid damaging accessories which may be secured inside the packaging. Examine the contents and check them off against the delivery note.

II - 1.2 STORAGE PRECAUTIONS

II - 1.2.1 Storage for less than six months

Equipment shall preferably be stored in its original packaging and protected from adverse weather conditions.

II - 1.2.2 Storage for more than six months

Store the pump in its original packaging. In addition, packaging in heat-sealing plastic cover and desiccant bags must be provided for. The quantity of desiccant bags should be adapted to the storage period and to the packaging volume. Store protected from adverse weather conditions.

II - 2. DESCRIPTION (See figure 1.1a)

The « SERIES G™ » Model A pump is a compact electromechanical metering pump that is life-lubricated with oil in a sealed housing, with capacity adjustment in operation or when stopped. It is made up of the following components:

It is made up of the following components:

- a drive device comprising a motor,
- a mechanical assembly,
- a liquid end.

The tightness/seal between mechanical part and the liquid end is made by a diaphragm.

The different parts of the pump are described on the below drawing 1.1a

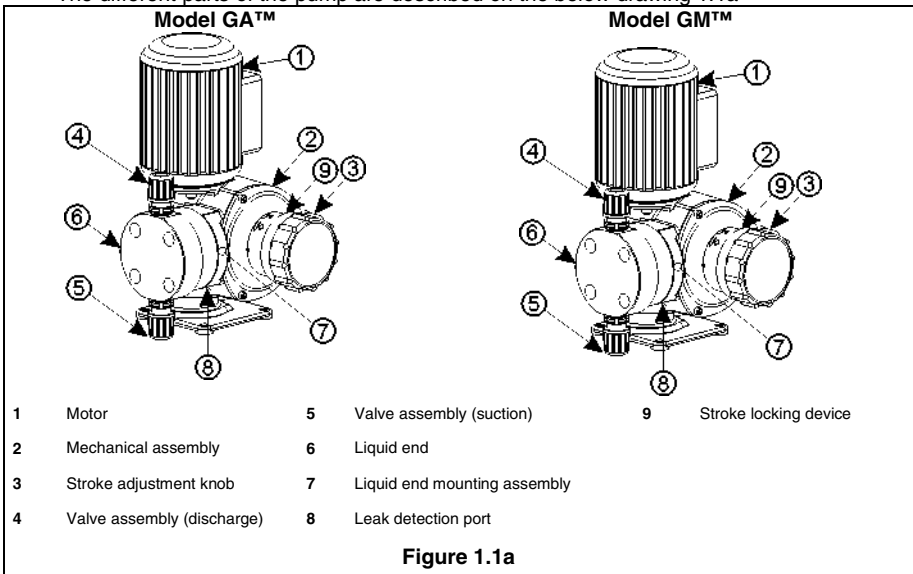

Figure 1.1a

For the stroke adjustment option, refer to the installation leaflet of the stroke adjustment option, delivered with the pump

II - 3. SAFETY AND HEALTH INSTRUCTIONS

The personnel responsible for installing, operating and maintaining this equipment must become acquainted with, assimilate and comply with the contents of this manual in order:

- Avoid any possible risk to themselves or to third parties,
- Ensure the reliability of the equipment
- Avoid any error or pollution due to incorrect operation.

Any servicing on this equipment must be carried out when it is stopped. Any accidental start-up must be prevented (either by locking the switch or removing the fuse on the power supply line).

A notice must be attached to the location of the switch to warn that servicing is being carried out on the equipment.

Switch off the power supply as soon as any fault is detected during operation:

- Abnormal heating or unusual noise.

Special care has to be taken for chemicals used in the process (acids, bases, oxidizing / reducing solutions, ...).

II - 4. ACCESSORIES (See Figure 1.2a)

Certain accessories are supplied as standard equipment or as options, as applicable.

- A foot valve (equipped with a filter). This avoids risk of unpriming the pump while filtering of the fluid.
- An injection nozzle: It isolates the liquid being pumped from the main flow and creates a back pressure necessary for proper running.

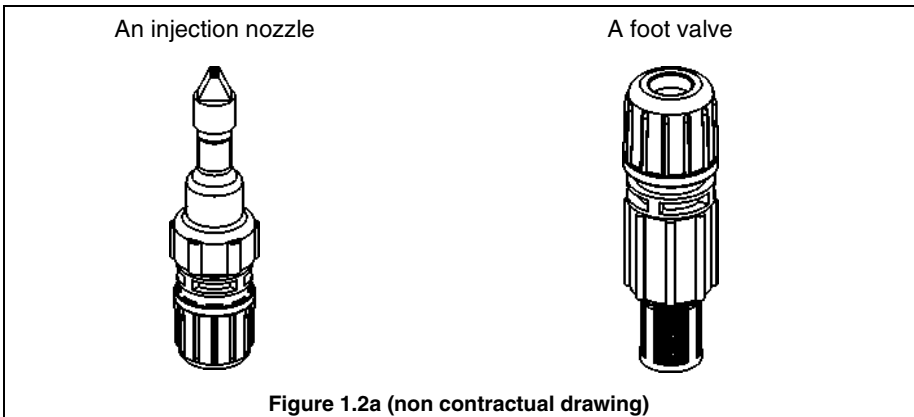

PART III - INSTALLATION

III - 1. TECHNICAL DATA

III - 1.1 COMMON TECHNICAL DATA

- Noise level, in dB A: < 70
- Ambient running temperature: -10°C - +40°C
- Max temperature of pumped liquids: -10°C - +40°C
- Flow and max allowable working pressure are indicated on the pump nameplate.
The running test is made with water and a motor running at 50Hz.

III - 1.2 GM PUMP - TECHNICAL DATA

CODE of pump	GM 2	GM 5	GM 10	GM 25	GM 50	GM 90	GM 120	GM 170	GM 240	GM 330	GM 400	GM 500
Steady state accuracy (flow rate 10% between 10% and 100%)	± 3%			± 1,5%								
Max. suction pressure, in bar (Pasp)	5				4				3			
Suction head, in meters water head (Ha)	4							2.5				

III - 1.3 GA PUMP - TECHNICAL DATA

CODE OF PUMP	GA2	GA5	GA10	GA25	GA45	GA90	GA120	GA170
Steady state accuracy (flow rate 10% between 10% and 100%)	± 2 %							
Max. suction pressure, in bar (Pasp)	2							
Max. suction pressure, in bar (Pasp)	4				2.5			

III – 1.4 LUBRIFICATION

The pump is life-lubricated with oil. However if for some reason oil needs to be replaced, refer to the specific manual included in the CD-Rom delivered with the pump.

III - 2. HYDRAULIC INSTALLATION

For information on hydraulic installation of a dosing pump, refer to the "Advice sheets" of the CD ROM provided with the pump. The main points are briefly described below.

III - 2.1 GENERAL (See figure 2.1b)

There must be no swan-necks or stagnant volumes which are liable to trap air or gas. Stresses due to incorrect alignment of piping with respect to the centreline of valves must be avoided as far as possible.

- Remove burrs and clean the piping before fitting.
- It is advisable to provide for a calibrating chamber in order to calibrate the pump in service conditions.

III - 2.2 PIPING ON THE SUCTION CIRCUIT (See figure 2.1b)

- If your pump is flooded, a shutt-off valve will be required (F 2.1d).
- If your pump is not flooded (suction lift), install the foot valve equipped with the filter upstream of the above-mentioned item(F 2.1c)
- For viscous products: consult us.
- Install the pump as near as possible to the suction tank.

III - 2.3 PIPING ON THE DISCHARGE CIRCUIT (See figure 2.1d)

- Provide for a safety valve on the discharge pipe, designed to protect the installation.
- It is advisable to install a priming valve on the maintenance of the pump easier.

III - 2.4 CONNECTION DEVICES (See figure 2.1a)

Use connection device adapted to your piping size.

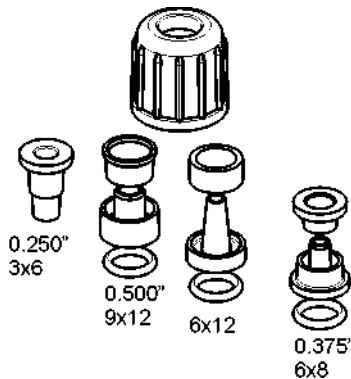

Figure 2.1a

III - 3. DRIP COLLECTION (See figure 1.1a.)

Provide for outlets so that any leak or drips can be easily drained off without any danger. This is especially important in the case of harmful liquids.

Position a tray under the plain hole located at the bottom of the liquid end mounting assembly to collect leaks in the event of rupture of the diaphragm or boot.

III - 4. HANDLING

The « SERIES G » Model A and M pump requires no special precautions owing to its light weight. Proceed with mounting as soon as it is set up on site.

III - 5. COMMISSIONING

Fix the pump to a horizontal support. Keep in mind to leaving sufficient space around the pump to allow maintenance and setting.

Pumps installed outside should be protected by a shelter (adapted to the climatic conditions of the location)

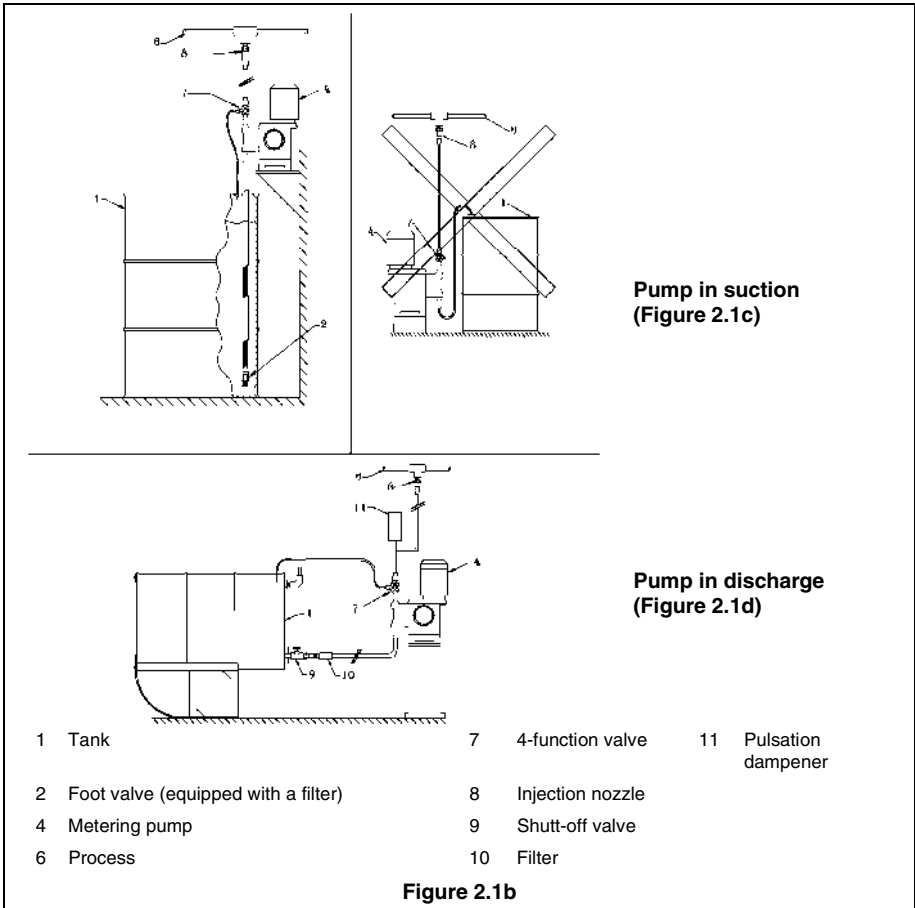

III - 6. ELECTRICAL INSTALLATION

III - 6.1 MOTOR CONNECTIONS

The characteristics of the electrical power supply do not match the specifications of the motor connections. Connect the motor as per electrical scheme indicated on the terminal box

Replace the existing cables by those of the electrical supply.



CAUTION: Do not forget to connect the earth terminal on the motor to the equipment earth conductor.

The electrical protection installed for the motor (fuse or thermal protection) must be suitable for the motor's rated current

PART IV - START UP

IV - 1. PROCEDURES BEFORE START UP

Special care has to be taken for chemicals used in the process (acids, bases, oxidizing/reducing solutions...).

- Check that the pump is secured to its support (Chapter III - 5. COMMISSIONING).
- Check the pipe fitting torque.
- Check the opening of all the isolating valves installed on the suction and discharge circuits. If your pump is equipped with a 4-function valve, see the relevant specific documentation. If the discharge circuit is equipped with an injection nozzle or a back-pressure valve, open the priming valve on the discharge side (if there is no priming valve, disconnect the piping on the discharge side). This allows you to check for the presence of liquid if the pump is installed in flooded suction or to prime the pump if it is installed in suction lift.
- Set the pump capacity adjustment to 0% (stroke adjustment knob)
- Check the compatibility of the liquid end material with the liquid to be pumped.

IV - 1.1 CHECKING THE ELECTRICAL CONNECTION OF THE MOTOR

Start up the pump to check the motor's direction of rotation. It must comply with that indicated by the arrow marked on the pump cover.

IV - 2 START UP

- Once all the checks and procedures described in the previous section have been carried out, start up the pump.
- Check visually and by listening. (In particular, check that there are no suspicious noises).
- Make sure that the stroke adjustment knob is unlocked.
- Adjust the pump capacity gradually from 0% to 100% and control either.
 - The liquid output at priming valve
 - or, the noise of the liquid when it discharges from the outlet check valve (if your installation is not equipped with a Priming Valve).
Priming has been achieved when one of these two processes is carried out.
If a Priming Valve is installed close it, otherwise connect the outlet discharge line.
- Set the pump to the desired capacity. Lock the stroke adjustment knob with the stroke locking device.

IV- 3. FAILURES ON START UP

IV - 3.1 PROBLEMS WITH MOTOR

The motor runs with difficulty and heats up.

- The characteristics of the electrical power supply do not match the specifications of the motor.

TRI Phase | One phase is incorrectly connected.
The electrical connection used is not suitable.

- Check that the pressure on the discharge side is compatible with the equipment's capabilities.
- Too many flow pulsations: a pulsation dampener is required, or the pulsation dampener installed is of the wrong size, or the pressurization of the pulsation dampener (2/3 of the working pressure).

TRI Phase | The direction of rotation of the motor is incorrect. (Check using the arrow marked on the cover). Reverse the direction Procedures. (See Chapter IV - 1.1. Checking the electrical connection of the motor).

IV - 3.2 PROBLEMS WITH FLOW RATE

The flow rate is lower than desired

- The pump capacity is incorrectly adjusted: adjust the capacity to the desired value and lock the stroke adjustment knob.
- The suction power is insufficient (Piping cross-section too small or piping too long): replace the pipes with ones with a larger cross-section or install the pump in flooded suction.
- The leak-tightness of the suction pipes is unsatisfactory.
- The viscosity of the liquid is incompatible with the capabilities offered by your pump version.
- The filter is blocked, clean it.

The capacity is greater than desired

- The pump capacity is incorrectly adjusted: adjust the capacity to the desired value and lock the stroke adjustment knob.
- A siphoning phenomenon is observed: check that the discharge pressure is higher by at least 1,5 bar than the suction pressure. Install a back pressure valve on the discharge portion
- Too many flow pulsations: a pulsation dampener is required, or the pulsation dampener installed is of the wrong size, or the pressurization of the pulsation dampener is incorrect.

The capacity is variable

- This problem may be due to particles from the piping which interfere with the operation of the valve assemblies: clean the piping and the valve assemblies.
- Lack of back pressure on the discharge portion: install a back pressure valve on the discharge portion

IV - 3.3 OPERATION - SCHEDULE FOR CHECKS AND MAINTENANCE OPERATIONS

The programme of checks and maintenance operations depends on the conditions in which the equipment is used. For the frequency of maintenance, refer to the instruction manual for installation, operating and maintenance included in the CD-Rom delivered with the pump. You can adapt the frequency to the conditions of your exploitation.

GUARANTEE

The vendor guarantees his products according to the Milton Roy Europe. General Conditions of Sale.

The guarantee for components and sub-assemblies not fabricated by the vendor is limited to that given by the supplier.

The vendor's guarantee only covers the replacement or the repair, at his cost and in his factory, of all parts acknowledged by his technical services as being defective due to an error in conception, of material or of execution.

It is the purchaser's responsibility to prove the said defects. The guarantee does not cover the replacement of wear parts mentioned in part V - Preventive Maintenance.

The vendor reserves the right to modify all or part of his products in order to satisfy the guarantee. The guarantee does not cover charges arising from dismantling, assembly, transport and movements.

The replacement of one or several parts, for whatever reason, does not prolong the period of guarantee.

The guarantee is not applicable notably in the following cases:

- Installation not in accordance with standard current practice.
- Deterioration or accident resulting from negligence.
- Lack of surveillance or maintenance.
- Modifications to conditions of use.
- Chemical corrosive or erosive attack. The proposed materials of construction are recommendations subject in all cases to verification and acceptance by the client. The recommendations, based on the experience of the vendor and the best available information, do not guarantee against wear or chemical action.

The guarantee ceases:

- If the storage of the material, out with the vendors factory, does not conform to his recommendations or to current standard practices.
- In case of work or dismantling of the material by someone who does not respect written recommendations of the instruction manual (when replacing wear parts).
- If parts from another origin are substituted for the original parts supplied by the manufacturer. The purchaser cannot call on guarantee claims to justify differing payments.

INDUSTRIAL OWNERSHIP

This manual can only be used by the purchaser or the user. It cannot be distributed, published, reproduced (partially or totally) or generally communicated to third parties without the advance, formal written authorisation of the vendor.

Any breach of these rules may result in legal action being taken.

F

FRANCE

ASSISTANCE TECHNIQUE : Tél.: 33.(0)2.32.68.30.02 Fax : 33.(0)2.32.68.30.96
PIECES DE RECHANGE : Tél.: 33 (0)2.32.68.30.01 Fax : 33.(0)2.32.68.30.92
ACCUEIL : Tél.: 33.(0)2.32.68.30.00 Fax : 33.(0)2.32.68.30.93
10 Grande Rue 27360 Pont-Saint-Pierre, France
www.dosapro.com email: contact@dosapro.com

USA

UNITED STATED

L.M.I. (LIQUID METRONICS, INC.)
Tél.: 978 263-9800 – Fax : 978 264-9172
8 Post Office Square Acton, MA 01720
www.lmipumps.com

FLOW CONTROL DIVISION :

TECHNICAL ASSISTANCE AND SPARE PARTS :
Tél.: 215.441.0800 – Fax : 215.293.0468
201 Ivyland Road, IVYLAND, PA, 18974
www.miltonroy.com email: customercervice@miltonroy.com

OTHER COUNTRIES :

Representatives in all countries, contact in FRANCE:
INTERNATIONAL SALE DEPARTMENT
Tél.: 33.2.32.68.3004 – Fax : 33.2.32.68.3094
www.dosapro.com email: contact@dosapro.com
